

Pilotless™ Mechanical Power Take-Off

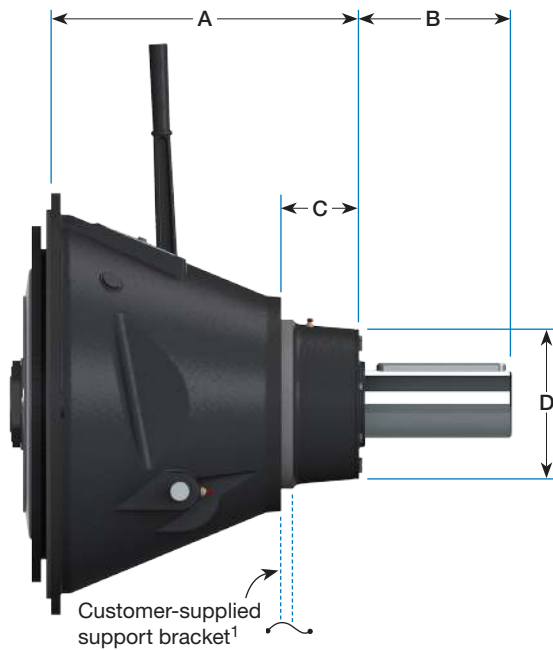

Industrial engine applications are more demanding than ever. Customers need a solution rugged enough to meet those demands and WPT Power has engineered that solution with the *WPT Pilotless™ Mechanical Power Take-Off*. This design eliminates the pilot bearing and increases side load capacity over previous generations of PTO products. The *WPT Pilotless™ Mechanical Power Take-Off* will optimize your cost by reducing inventory, increasing uptime and engine life, and simplify installation time.



- Dual spherical roller main bearing design.
- Time savings for assembly since no pilot bearing alignment required.
- Most sizes fit within envelope of previous design.
- No direct loading to engine crankshaft increases life of engine main bearings.
- No installation related engine thrust bearing damage.
- 100% equipped with ball-bearing engagement collars.
- Increased side load capacity.

Model	SAE Housings	A	Output Shaft			C	D	Weight lb (kg)	# of Teeth
			B	Dia	Keyway				
WPL 106	5, 4	8 7/16 (214.6)	2 1/8 (55.4)	1.438 (36.53)	3/8 x 3/16	2 7/16 (62.7)	4 7/16 (112.8)	72 (33)	42
WPL 107	5, 4	8 7/16 (214.6)	2 1/8 (55.4)	1.438 (36.53)	3/8 x 3/16	2 7/16 (62.7)	4 7/16 (112.8)	75 (134)	47
WPL 108	4	8 3/8 (213.4)	4 5/8 (118.4)	1.750 (44.45)	1/2 x 1/4	3 (76.7)	4 13/16 (122.9)	88 (40)	51
WPL 110	4, 3	9 3/4 (248.4)	3 15/16 (100.1)	2.250 (57.15)	5/8 x 5/16	3 1/2 (89.4)	5 3/4 (146.1)	125 (57)	63
WPL 111	3	11 7/16 (291.7)	4 1/16 (102.6)	2.250 (57.15)	5/8 x 5/16	11 1/8 (282.7)	5 3/4 (146.1)	162 (73)	72
WPL 211	3, 2	12 9/16 (320.0)	3 5/8 (92.5)	2.500 (63.50)	5/8 x 5/16	4 1/4 (108.0)	6 3/4 (171.5)	218 (99)	72
WPL 311 ¹	3, 2	15 3/4 (400.8)	8 (204.0)	3.500 (88.90)	7/8 x 7/16	3 11/16 (94.2)	7 3/4 (196.9)	343 (156)	72
WPL 114	1	13 5/8 (346.2)	5 1/8 (130.6)	3.000 (76.20)	3/4 x 3/8	3 3/4 (95.2)	6 3/4 (171.5)	275 (125)	59
WPL 214 ¹	1, 0	16 3/16 (411.5)	7 1/2 (191.8)	3.500 (88.90)	7/8 x 7/16	4 5/16 (110.2)	7 3/4 (196.9)	407 (185)	59
WPL 314 ¹	1, 0	17 1/16 (433.1)	7 1/2 (190.5)	3.938 (100.01)	1 x 1/2	3 7/8 (99.6)	8 1/4 (209.6)	470 (213)	59

¹ Support plate for 311, 214, 314 is required for sideload applications and recommended for inline applications.

PTO Product Selection Guide

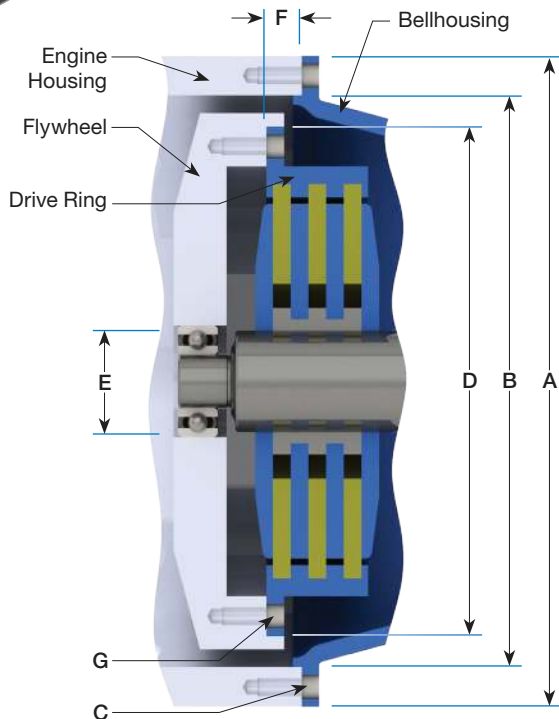

WPT SAE Housing Adapters Available

Part Number	From SAE Engine Housing	To SAE Bellhousing
WTD-00-000	2	4
WTD-00-001	1	2
WTD-00-002	1/2	1
WTD-00-003	0	1
WTD-00-004	00	0

WPT PTOs meet the mounting requirements of SAE J617 and SAE J620.

Dual or double-drilled flywheels may interfere with PTO. Contact WPT Applications Engineering for assistance on higher capacity or speed rating questions.

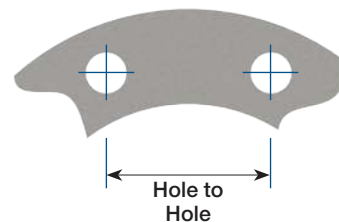

Housing						
SAE Housing	A	B Pilot	C			
			Bolt Circle	Qty	Dia	Hole to Hole
6	12 1/8 (307.8)	10.500 (266.70)	11.25 (285.8)	8	13/32 (10.3)	4 1/4 (109.4)
5	14 (355.6)	12.375 (314.32)	13.13 (333.4)	8	13/32 (10.3)	5 (127.6)
4	15 7/8 (403.4)	14.250 (361.95)	15.00 (381.0)	12	13/32 (10.3)	3 7/8 (98.6)
3	17 3/4 (450.8)	16.125 (409.58)	16.88 (428.6)	12	13/32 (10.3)	4 5/16 (110.9)
2	19 1/4 (489.0)	17.625 (447.68)	18.38 (466.7)	12	13/32 (10.3)	4 3/4 (120.8)
1	21 3/4 (552.4)	20.125 (511.18)	20.88 (530.2)	12	15/32 (11.9)	5 3/8 (137.2)
1/2	25 1/2 (647.7)	23.000 (584.20)	24.38 (619.1)	12	17/32 (11.5)	6 1/4 (160.2)
0	28 (711.2)	25.500 (647.70)	26.75 (679.5)	16	17/32 (11.5)	5 3/16 (132.6)
00	34 3/4 (882.6)	31.000 (787.40)	33.50 (850.9)	16	17/32 (11.5)	6 1/2 (166.0)

Flywheel							
WPT Clutch Size	D Pilot	E (mm)	F	G			
				Bolt Circle	Qty	Dia	Hole to Hole
6"	8.500 (215.90)	52	1 3/16 (30.2)	7.88 (200.0)	6	21/64 (8.3)	3 15/16 (100.0)
7"	9.500 (241.30)	52	1 3/16 (30.2)	8.75 (222.3)	8	21/64 (8.3)	3 5/16 (85.1)
8"	10.375 (263.52)	62	2 7/16 (62.0)	9.63 (244.5)	6	13/32 (10.3)	4 3/4 (122.2)
10"	12.375 (314.32)	62 72	2 1/8 (53.8)	11.63 (295.3)	8	13/32 (10.3)	4 7/16 (113.0)
11"	13.875 (352.42)	62 72 80	1 9/16 (39.6)	13.13 (333.4)	8	13/32 (10.3)	5 (127.6)
14"	18.375 (466.72)	72 80 100	1 (25.4)	17.25 (438.2)	8	17/32 (13.5)	6 9/16 (167.7)
18"	22.500 (571.50)	100 120	5/8 (15.7)	21.38 (542.9)	6	21/32 (16.7)	10 11/16 (271.5)
21"	26.500 (673.10)	-	0 (0)	25.25 (641.4)	12	21/32 (16.7)	6 1/2 (166.0)

PTO Product Selection Guide



► Step One

Application Service Factor Selection Guide

Service Factor (SF)

	Duty Service Classification	Typical Applications	Single Cylinder Engine		Multi-Cylinder Engine	
			Up to 10 Hours/Day	Over 10 Hours/Day	Up to 10 Hours/Day	Over 10 Hours/Day
Uniform	Light loads with minimal slip	Centrifugal blowers, compressors, fans, rotary pumps	1.5	1.75	1.25	1.5
Moderate	Medium loads with maximum 3 second slip at engagement	Cone crushers, wood chippers, mine fans, reciprocating pumps, road milling machines and planers	2	2.25	1.75	2
Severe	Heavy loads requiring bump start sequence for engagement	Jaw crushers, tub grinders, dredge/mud pumps, hammer mills, reciprocating compressors, waste recyclers	2.25	2.5	2	2.25

► Step Two

Maximum Input Torque

$$T = \frac{\text{hp} \times \text{SF}}{\text{r/min}} \times 5,252 = \text{_____ lbf-ft}$$

$$T = \frac{\text{kW} \times \text{SF}}{\text{r/min}} \times 9,549 = \text{_____ N-m}$$

$$T = \text{Engine Torque [lbf-ft (N-m)]} \times \text{SF}$$

Conversions		
Multiply	By	To Obtain
lbf-ft	1.356	N-m
hp	0.746	kW
lbf	0.454	kgf
kg	9.807	N

► Step Three

For in-line applications skip to Step Four.

Sideload

$$L = \frac{\text{hp} \times F \times \text{SF}}{\text{r/min} \times D \text{ (in)}} \times 126,000 = \text{_____ lbf}$$

$$L = \frac{\text{kW} \times F \times \text{SF}}{\text{r/min} \times D \text{ (mm)}} \times 1,947,000 = \text{_____ kgf}$$

L = Actual Applied sideload
D = Sheave or Sprocket Diameter
F = Load Factor
 1.0 for Chain Drive or Gear Belt
 1.5 for Timing Belts
 2.2 for All V-belts

► Step Four

See Pages 14 and 15 for PTO Maximum Input Torque, r/min and Sideload ratings.

Additional Notes:

Power Take-Off calculations are for reference only. For full warranty consideration, a data sheet must be turned into WPT Power and complete review performed by WPT Power Applications Engineering.

Pilotless™/OTS/Automotive Performance Ratings

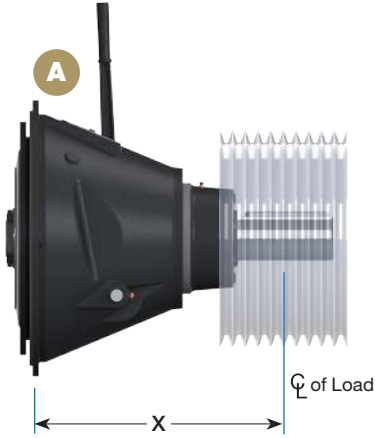

A Pilotless™ Mechanical

Model	"X" Distance Inches (mm) · Allowable Sideload ¹ lbf (kgf)					Maximum Input Torque ¹ lbf-ft (N-m)	Maximum Speed ¹ r/min
	r/min	"X"	Sideload	"X"	Sideload		
WPL 106	1800	10 (254)	1,610 (730)	11 (279)	1,360 (610)	171 (232)	3500
	2500		1,610 (730)		1,360 (610)		
	3500		1,540 (700)		1,290 (590)		
WPL 107	1800	10 (254)	1,610 (730)	11 (279)	1,360 (610)	191 (259)	3200
	2500		1,610 (730)		1,360 (610)		
	3200		1,580 (720)		1,330 (600)		
WPL 108	2100	11 (279)	1,900 (860)	13 (330)	1,250 (570)	248 (336)	3100
	2400		1,900 (860)		1,250 (560)		
	3100		1,710 (780)		1,130 (510)		
WPL 110	2100	12 (305)	2,370 (1070)	14 (356)	1,810 (820)	354 (481)	2800
	2300		2,310 (1050)		1,780 (810)		
	2500		2,250 (1020)		1,740 (790)		
WPL 111	2100	13 (330)	3,100 (1410)	15 (381)	2,410 (1090)	487 (660)	2500
	2300		3,020 (1370)		2,350 (1060)		
	2500		2,940 (1340)		2,290 (1040)		
WPL 211	2100	14 (356)	4,750 (2160)	16 (406)	3,690 (1670)	974 (1321)	2500
	2300		4,630 (2100)		3,590 (1630)		
	2500		4,510 (2050)		3,500 (1590)		
WPL 311	2100	19 (483)	3,670 (1660)	23 (584)	2,500 (1130)	1746 (2367)	2500
	2300		3,570 (1620)		2,430 (1100)		
	2500		3,480 (1580)		2,370 (1080)		
WPL 114	1800	16 (406)	3,150 (1430)	18 (457)	2,490 (1130)	862 (1169)	2300
	2100		3,000 (1360)		2,380 (1080)		
	2300		2,920 (1330)		2,310 (1050)		
WPL 214	1800	20 (508)	3,890 (1770)	24 (610)	2,760 (1250)	1724 (2337)	2300
	2100		3,720 (1690)		2,640 (1200)		
	2300		3,620 (1640)		2,570 (1160)		
WPL 314	1800	22 (559)	4,040 (1830)	24 (610)	3,420 (1550)	2586 (3506)	2300
	2100		3,850 (1750)		3,270 (1480)		
	2300		3,750 (1700)		3,180 (1440)		

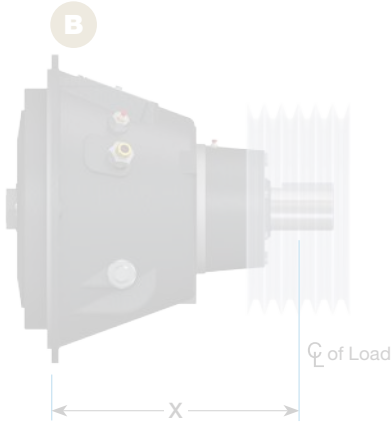

B Pilotless™ Over-the-Shaft

Model	"X" Distance Inches (mm) Allowable Sideload ¹ lbf (kgf)			Maximum Input Torque lbf-ft (N-m) at 100 lbf/in ² [7 bar]	Maximum Input Torque ¹ lbf-ft (N-m) at 200 lbf/in ² [14 bar]	Maximum Speed ¹ r/min
	r/min	"X"	Sideload			
OTS-PL 211	2100	14 (356)	4,750 (2160)	810 (1100)	1770 (2400)	2500
	2300		4,630 (2100)			
	2500		4,510 (2050)			
OTS-PL 311	2100	19 (483)	3,670 (1660)	1250 (1700)	2580 (3500)	2500
	2300		3,570 (1620)			
	2500		3,480 (1580)			
OTS-PL 214	1800	20 (508)	3,890 (1770)	740 (1000)	1860 (2525)	2300
	2100		3,720 (1690)			
	2300		3,620 (1640)			
OTS-PL 314	1800	22 (559)	4,040 (1830)	1360 (1500)	2780 (3770)	2300
	2100		3,850 (1750)			
	2300		3,750 (1700)			

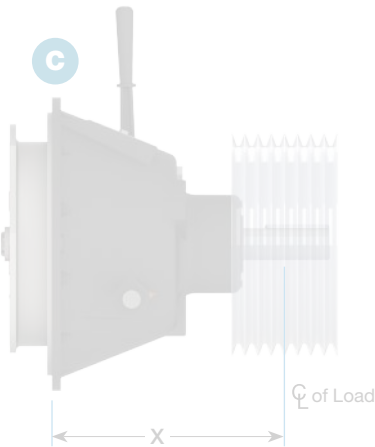

C Automotive

Model	"X" Distance Inches (mm) · Allowable Sideload ¹ lbf (kgf)					Maximum Input Torque ¹ lbf-ft (N-m)	Maximum Speed ¹ r/min
	r/min	"X"	Sideload	"X"	Sideload		
WTD-13-130	2000	10 (254)	1,000 (500)	13 (330)	700 (300)	412 (560)	3500
	3000		900 (400)		600 (300)		3000
WTD-13-133	2000	10 (254)	2,600 (1200)	13 (330)	1,700 (800)	412 (560)	3000
	3000		2,300 (1000)		1,500 (700)		
W15-WG-200	2000	10 (254)	1,000 (500)	13 (330)	500 (200)	1650 (2200)	2100
	3000		900 (400)		400 (200)		
GM® Style	2000	15 (381)	1,000 (500)	18 (457)	700 (300)	386 (523)	3400
	3000		900 (400)		600 (300)		
GM® Style HD	2000	15 (381)	2,900 (1300)	18 (457)	2,000 (900)	386 (523)	3400
	3000		2,900 (1300)		2,000 (900)		

¹ Contact WPT Applications Engineering for assistance on higher capacity or speed rating questions.