

# Mechanical Power Take-Off

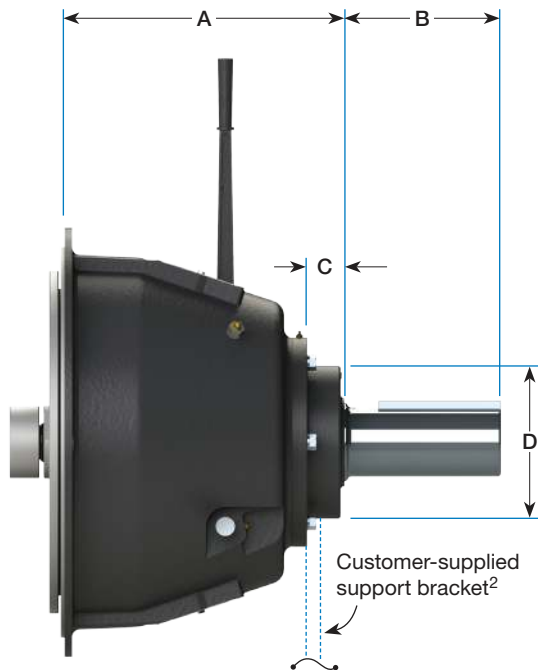

The WPT® Mechanical Power Take-Off consists of a lever-actuated clutch with a shaft and bearings mounted in a rigid cast housing. The Mechanical PTO is designed for inline and sideload applications on all internal combustion engines with standard SAE industrial flywheel/flywheel housing dimensions.

- Sealed-for-life pilot bearings eliminate lubrication problems.
- Ball bearing throwout collars are optional on 10", 11 1/2", 14" and 18". Standard on the 311 PTO.
- All drive rings are ductile (nodular) iron or steel.

Model	SAE Housings	A	Output Shaft			C	D	Weight lb (kg)	# of Teeth
			B	Dia	Keyway				
C106 <sup>1</sup> C107 <sup>1</sup>	5, 4	7 1/8 (181.0)	3 1/2 (88.9)	1.438 (36.53)	3/8 x 3/16	2 1/8 (54.0)	4 5/8 (117.5)	65 (30)	42
C108	5, 4, 3	7 1/8 (181.0)	6 (152.4)	1.750 (44.45)	1/2 x 1/4	2 1/4 (57.2)	5 (127.0)	82 (37)	51
C110	4, 3	8 5/8 (219.1)	5 1/2 (139.7)	2.250 (57.15)	5/8 x 5/16	3 3/4 (95.3)	5 5/8 (142.9)	117 (53)	63
SP111	3, 2, 1	9 1/4 (235.0)	6 1/2 (165.1)	2.250 (57.15)	5/8 x 5/16	3 3/4 (95.3)	5 3/4 (146.1)	143 (65)	72
SP211	3, 2, 1	9 5/8 (244.5)	6 1/2 (165.1)	2.500 (63.50)	5/8 x 5/16	3 (76.2)	6 1/4 (158.8)	157 (71)	72
SP311 <sup>2</sup>	3, 2	13 7/8 (352.4)	10 (254.0)	3.500 (88.90)	7/8 x 7/16	3 3/8 (85.7)	7 1/2 (190.5)	233 (106)	72
SP114	1	12 1/8 (308.0)	8 1/2 (215.9)	3.000 (76.20)	3/4 x 3/8	3 3/4 (95.3)	6 5/8 (168.3)	263 (119)	59
SP214 <sup>2</sup>	1, 0	13 3/4 (349.3)	10 (254.0)	3.500 (88.90)	7/8 x 7/16	3 3/8 (85.7)	7 1/2 (190.5)	332 (151)	59
SP314 <sup>2</sup>	1, 0	14 1/2 (368.3)	10 (254.0)	3.938 (100.01)	1 x 1/2	3 3/8 (85.7)	7 1/2 (190.5)	413 (187)	59
IBF314 <sup>2</sup>	1, 0	16 3/4 (425.5)	10 (254.0)	3.938 (100.01)	1 x 1/2	3 5/8 (92.1)	12 1/2 (317.5)	595 (270)	59
SP318 <sup>2</sup>	0	18 1/4 (463.6)	10 (254.0)	4.500 (114.30)	1 x 1/2	2 5/8 (66.7)	10 (254.0)	897 (407)	75

<sup>1</sup> Double main bearings

<sup>2</sup> Support plate for 311, 214, 314 is required for sideload applications and recommended for inline applications. Support plate for 318 is required for both sideload and inline applications.

# PTO Product Selection Guide

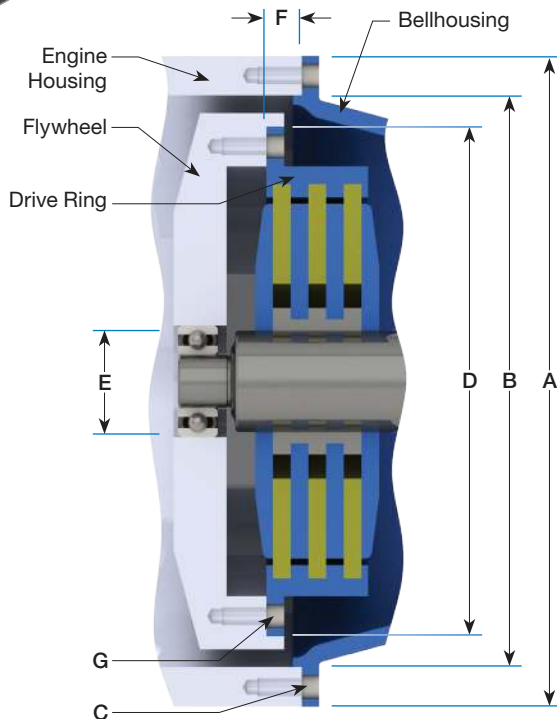

## WPT SAE Housing Adapters Available

Part Number	From SAE Engine Housing	To SAE Bellhousing
WTD-00-000	2	4
WTD-00-001	1	2
WTD-00-002	1/2	1
WTD-00-003	0	1
WTD-00-004	00	0

WPT PTOs meet the mounting requirements of SAE J617 and SAE J620.

Dual or double-drilled flywheels may interfere with PTO. Contact WPT Applications Engineering for assistance on higher capacity or speed rating questions.

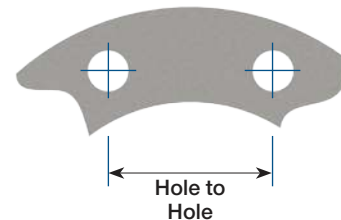

## Housing

SAE Housing	A	B Pilot	C			
			Bolt Circle	Qty	Dia	Hole to Hole
6	12 1/8 (307.8)	10.500 (266.70)	11.25 (285.8)	8	13/32 (10.3)	4 1/4 (109.4)
5	14 (355.6)	12.375 (314.32)	13.13 (333.4)	8	13/32 (10.3)	5 (127.6)
4	15 7/8 (403.4)	14.250 (361.95)	15.00 (381.0)	12	13/32 (10.3)	3 7/8 (98.6)
3	17 3/4 (450.8)	16.125 (409.58)	16.88 (428.6)	12	13/32 (10.3)	4 5/16 (110.9)
2	19 1/4 (489.0)	17.625 (447.68)	18.38 (466.7)	12	13/32 (10.3)	4 3/4 (120.8)
1	21 3/4 (552.4)	20.125 (511.18)	20.88 (530.2)	12	15/32 (11.9)	5 3/8 (137.2)
1/2	25 1/2 (647.7)	23.000 (584.20)	24.38 (619.1)	12	17/32 (11.5)	6 1/4 (160.2)
0	28 (711.2)	25.500 (647.70)	26.75 (679.5)	16	17/32 (11.5)	5 3/16 (132.6)
00	34 3/4 (882.6)	31.000 (787.40)	33.50 (850.9)	16	17/32 (11.5)	6 1/2 (166.0)

## Flywheel

WPT Clutch Size	D Pilot	E (mm)	F	G			
				Bolt Circle	Qty	Dia	Hole to Hole
6"	8.500 (215.90)	52	1 3/16 (30.2)	7.88 (200.0)	6	21/64 (8.3)	3 15/16 (100.0)
7"	9.500 (241.30)	52	1 3/16 (30.2)	8.75 (222.3)	8	21/64 (8.3)	3 5/16 (85.1)
8"	10.375 (263.52)	62	2 7/16 (62.0)	9.63 (244.5)	6	13/32 (10.3)	4 3/4 (122.2)
10"	12.375 (314.32)	62 72	2 1/8 (53.8)	11.63 (295.3)	8	13/32 (10.3)	4 7/16 (113.0)
11"	13.875 (352.42)	62 72 80	1 9/16 (39.6)	13.13 (333.4)	8	13/32 (10.3)	5 (127.6)
14"	18.375 (466.72)	72 80 100	1 (25.4)	17.25 (438.2)	8	17/32 (13.5)	6 9/16 (167.7)
18"	22.500 (571.50)	100 120	5/8 (15.7)	21.38 (542.9)	6	21/32 (16.7)	10 11/16 (271.5)
21"	26.500 (673.10)	-	0 (0)	25.25 (641.4)	12	21/32 (16.7)	6 1/2 (166.0)

# PTO Product Selection Guide



## ► Step One

### Application Service Factor Selection Guide

### Service Factor (SF)

	Duty Service Classification	Typical Applications	Single Cylinder Engine		Multi-Cylinder Engine	
			Up to 10 Hours/Day	Over 10 Hours/Day	Up to 10 Hours/Day	Over 10 Hours/Day
Uniform	Light loads with minimal slip	Centrifugal blowers, compressors, fans, rotary pumps	1.5	1.75	1.25	1.5
Moderate	Medium loads with maximum 3 second slip at engagement	Cone crushers, wood chippers, mine fans, reciprocating pumps, road milling machines and planers	2	2.25	1.75	2
Severe	Heavy loads requiring bump start sequence for engagement	Jaw crushers, tub grinders, dredge/mud pumps, hammer mills, reciprocating compressors, waste recyclers	2.25	2.5	2	2.25

## ► Step Two

Maximum Input Torque

$$T = \frac{\text{hp} \times \text{SF}}{\text{r/min}} \times 5,252 = \text{_____ lbf-ft}$$

$$T = \frac{\text{kW} \times \text{SF}}{\text{r/min}} \times 9,549 = \text{_____ N-m}$$

$$T = \text{Engine Torque [lbf-ft (N-m)]} \times \text{SF}$$

Conversions		
Multiply	By	To Obtain
lbf-ft	1.356	N-m
hp	0.746	kW
lbf	0.454	kgf
kg	9.807	N

## ► Step Three

*For in-line applications skip to Step Four.*

Sideload

$$L = \frac{\text{hp} \times F \times \text{SF}}{\text{r/min} \times D \text{ (in)}} \times 126,000 = \text{_____ lbf}$$

$$L = \frac{\text{kW} \times F \times \text{SF}}{\text{r/min} \times D \text{ (mm)}} \times 1,947,000 = \text{_____ kgf}$$

**L** = Actual Applied sideload  
**D** = Sheave or Sprocket Diameter  
**F** = Load Factor  
 1.0 for Chain Drive or Gear Belt  
 1.5 for Timing Belts  
 2.2 for All V-belts

## ► Step Four

*See Pages 14 and 15 for PTO Maximum Input Torque, r/min and Sideload ratings.*

### Additional Notes:

Power Take-Off calculations are for reference only. For full warranty consideration, a data sheet must be turned into WPT Power and complete review performed by WPT Power Applications Engineering.

# Mechanical/Type 1/Type 2 Performance Ratings

## D Mechanical

"X" Distance Inches (mm) · Allowable Sideload <sup>1</sup> lbf (kgf)						Maximum Input Torque <sup>1</sup> lbf-ft (N·m)	Maximum Speed <sup>1</sup> r/min
Model	r/min	"X"	Sideload	"X"	Sideload		
C106	1800	8	600 (300)	9	500 (200)	171 (232)	3500
C107	3500	(203)	500 (200)	(229)	400 (200)	191 (259)	3200
(Double Main Bearings)							
C106	1800	9	1,000 (400)	10	800 (400)	171 (232)	3500
C107	3200	(229)	800 (400)	(254)	600 (300)	191 (259)	3200
C108	1800	10	1,300 (600)	12	900 (400)	248 (336)	3100
	3100	(254)	1,100 (500)	(305)	800 (400)		
C110	1800	12	2,000 (900)	14	1,400 (600)	354 (481)	2800
	2800	(305)	1,700 (800)	(356)	1,200 (600)		
SP111	1800	12	2,100 (1000)	14	1,500 (700)	487 (660)	2500
	2500	(305)	1,900 (900)	(356)	1,300 (600)		
SP211	1800	13	2,100 (900)	15	1,500 (700)	974 (1321)	2500
	2500	(330)	1,900 (800)	(381)	1,300 (600)		
SP311	1800	18	2,000 (900)	22	1,300 (300)	1746 (2367)	2300
	2300	(457)	1,900 (900)	(559)	1,200 (500)		
SP114	1800	16	2,000 (900)	22	1,200 (500)	862 (1169)	2300
	2300	(406)	2,200 (1000)	(508)	1,400 (600)		
SP214	1800	18	2,900 (1300)	20	1,200 (500)	1724 (2337)	2300
	2300	(457)	2,300 (1000)	(559)	1,400 (700)		
SP314 (80 mm PB)	1800	19	2,700 (1200)	23	1,700 (800)	2586 (3506)	2300
	2300	(483)	2,500 (1100)	(584)	1,500 (700)		
SP314 (100mm PB)	1800	19	3,800 (1700)	23	2,500 (1100)	2586 (3506)	2300
	2800	(483)	3,800 (1700)	(584)	2,400 (1100)		
IBF314	1800	22	5,500 (2500)	27	4,600 (2100)	2586 (3506)	2300
	2300	(559)	6,000 (2700)	(686)	5,000 (2300)		
SP318	1800	23	6,020 (2730)	27	3,910 (1770)	6465 (8765)	2100
	2100	(584)	6,340 (2880)	(686)	4,110 (1860)		

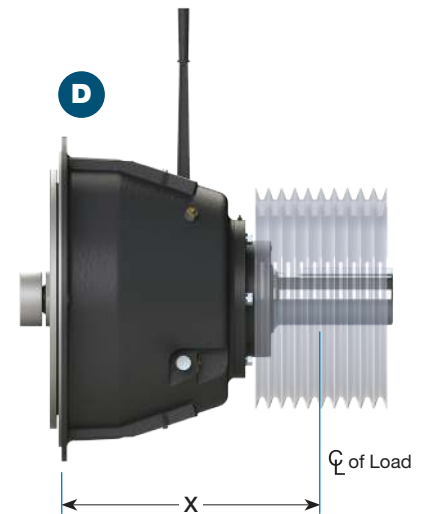

## E Type 1

"X" Distance Inches (mm) · Allowable Sideload <sup>1</sup> lbf (kgf)						Maximum Input Torque <sup>1</sup> lbf-ft (N·m)	Maximum Speed <sup>1</sup> r/min
Model	RPM	"X"	Sideload	"X"	Sideload		
314H (GEN II)	1800	17	15,100 (6900)	19	12,400 (5600)	3,800 (5100)	2300
SP314 (GEN II)	2300	(432)	14,100 (6400)	(483)	11,500 (5200)		
318	1800	22	28,300 (12800)	26	21,700 (9900)	7,100 (9600)	2100
	2100	(559)	27,000 (12300)	(660)	19,800 (9000)		
321	1200	28	31,700 (14400)	32	24,400 (11100)	13,500 (18300)	1800
	1800	(711)	28,800 (13100)	(813)	22,200 (10100)		

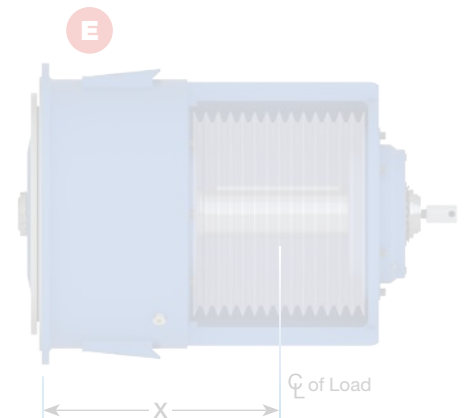

## F Type 2

"X" Distance Inches (mm) · Allowable Sideload <sup>1</sup> lbf (kgf)						Maximum Input Torque <sup>1</sup> lbf-ft (N·m)	Maximum Speed <sup>1</sup> r/min
Model	r/min	"X"	Sideload	"X"	Sideload		
211	2100	12	3,500 (1600)	15	2,400 (1100)	1,300 (1800)	2500
	2500	(305)	3,300 (1500)	(381)	2,300 (1000)		
311	2100	12	3,500 (1600)	15	2,400 (1100)	1,900 (2600)	2500
	2500	(305)	3,300 (1500)	(381)	2,300 (1000)		
214H Compact	1800	16	5,300 (2400)	19	3,800 (1700)	2,500 (3400)	2300
	2300	(406)	5,300 (2400)	(483)	3,500 (1600)		
214H	1800	23	8,000 (3600)	29	5,500 (2500)	2,500 (3400)	2300
	2300	(584)	7,600 (3500)	(737)	5,300 (2400)		
314H Compact	1800	16	5,300 (2400)	19	3,800 (1700)	3,800 (5100)	2300
	2300	(406)	5,300 (2400)	(483)	3,500 (1600)		
314H	1800	23	8,000 (3600)	29	5,500 (2500)	3,800 (5100)	2300
	2300	(584)	7,600 (3500)	(737)	5,300 (2400)		
218	1800	23	8,000 (3600)	29	5,500 (2500)	4,700 (6400)	2100
	2300	(584)	7,600 (3500)	(737)	5,300 (2400)		
318	1800	23	8,000 (3600)	29	5,500 (2500)	7,100 (9600)	2100
	2300	(584)	7,600 (3500)	(737)	5,300 (2400)		
318 Heavy Duty	1800	17	16,600 (7500)	20	12,000 (5400)	7,100 (9600)	2100
	2100	(432)	15,800 (7200)	(508)	11,500 (5200)		

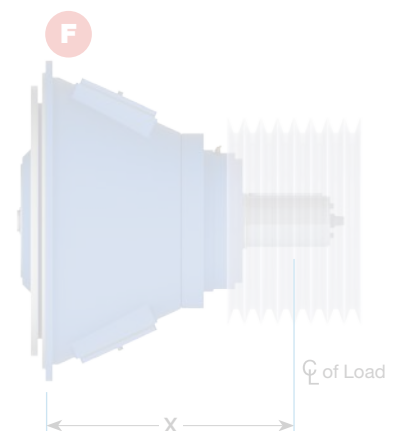

<sup>1</sup> Contact WPT Applications Engineering for assistance on higher capacity or speed rating questions.