

# Rockford - NACD Style

Standard Power Take-Offs

with **10" HE** Clutches

Foley Engines

Shipping Address:  
200 Summer Street

Worcester, MA 01604

Phone:  
(508) 753-2979  
(800) 233-6539

Fax:  
+1 (508) 831-7133

Email:  
info@foleyengines.com

<https://www.foleyengines.com>

Manufacturers names, symbols and numbers are for reference purposes only and do not imply manufacturing origin.

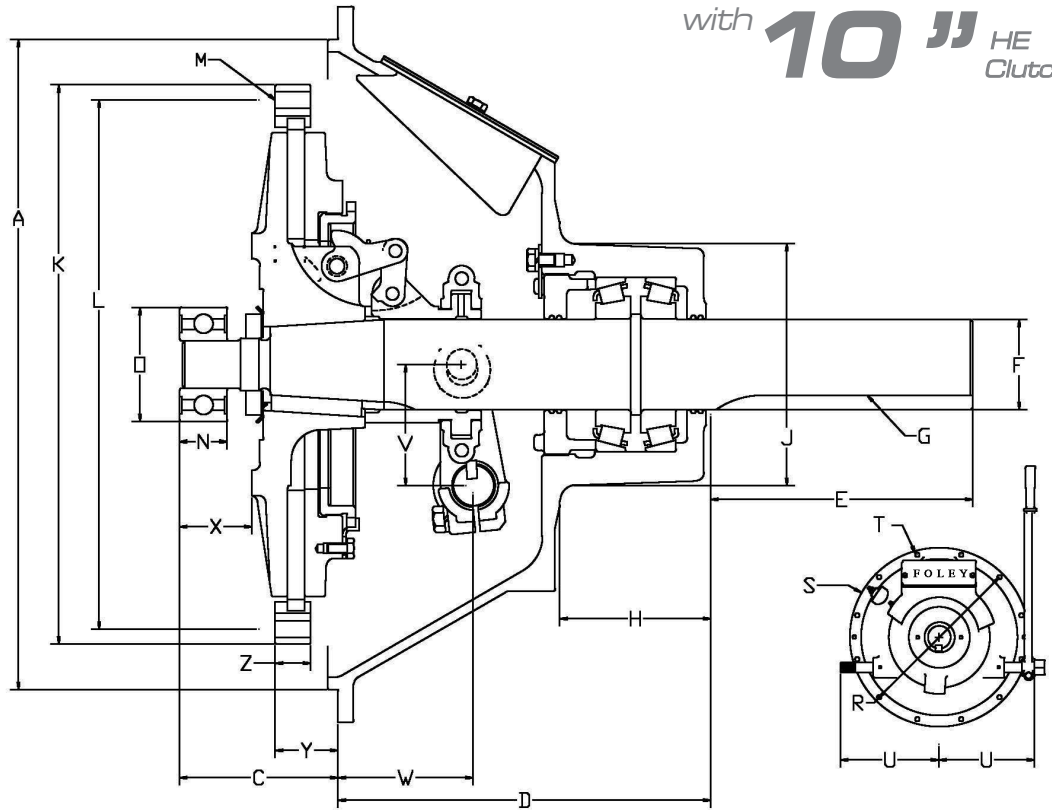

PTO Part Number	Ball or Tapered Roller Brng Type	Model			Application (in-line or side loaded)	Type of Facing	Type Release Bearing	Clutch Torque Capacity lb. Ft *	A	C	D	Shaft		
		SAE Hsg Size	Clutch Size	Qty. of Facings								E Length	F Dia. + .000-.001	G Keyway
411256FO	Tapered	4	10"	1	Both	Organic	Bronze	460	14.25	3.94	8.62	5.50	2.250	5/8 x 5/16
411256FO2	Tapered	4	10"	1	Both	Organic	Bronze	460	14.25	3.94	8.62	4.14	2.250	5/8 x 5/16
411256FO3	Tapered	4	10"	1	Both	Organic	Bronze	460	14.25	3.94	8.62	5.50	2.250	5/8 x 5/16
411256FO4	Tapered	4	10"	1	Both	Organic	Bronze	460	14.25	3.94	8.62	3.13	2.250	5/8 x 5/16
411256FO5	Tapered	4	10"	1	Both	Organic	Bronze	460	14.25	3.94	8.62	5.50	2.250	5/8 x 5/16
411256FO7	Tapered	4	10"	1	Both	Organic	Bronze	460	14.25	3.94	8.62	5.50	2.250	5/8 x 5/16
434630FO1	Tapered	4	10"	1	Both	Organic	Ball	460	14.25	3.94	8.62	5.50	2.250	5/8 x 5/16
434630FO2	Tapered	4	10"	1	Both	Organic	Ball	460	14.25	3.94	8.62	5.50	2.250	5/8 x 5/16
434630FO3	Tapered	4	10"	1	Both	Organic	Ball	460	14.25	3.94	8.62	4.14	2.250	5/8 x 5/16
436003FO	Tapered	3	10"	1	Both	Organic	Bronze	460	16.125	3.94	9.25	5.50	2.250	5/8 x 5/16
436003FO1	Tapered	3	10"	1	Both	Organic	Bronze	460	16.125	3.94	9.25	5.50	2.250	5/8 x 5/16
434240FO	Tapered	3	10"	1	Both	Organic	Ball	460	16.125	3.94	9.25	5.50	2.250	5/8 x 5/16
434240FO1	Tapered	3	10"	1	Both	Organic	Ball	460	16.125	3.94	9.25	5.50	2.250	5/8 x 5/16
431271FO	Tapered	2	10"	1	Both	Organic	Bronze	460	17.625	3.94	9.25	5.50	2.250	5/8 x 5/16

PTO Part Number	H	J	K	L	M (holes)		N	O see note**	R	S	T (holes)		U	V	W	X	Y	Z
					Qty.	Dia.					Qty.	Dia.						
411256FO	3.75	6.00	12.375	11.625	8	.406	1.1875	2.8346	15.000	15.88	12	.433	7.75	3.00	3.25	1.44	2.12	.88
411256FO2	3.75	6.00	12.375	11.625	8	.406	1.1875	2.8346	15.000	15.88	12	.433	7.75	3.00	3.25	1.44	2.12	.88
411256FO3	3.75	6.00	12.375	11.625	8	.406	.937	2.440	15.000	15.88	12	.433	7.75	3.00	3.25	1.44	2.12	.88
411256FO4	3.75	6.00	12.375	11.625	8	.406	1.1875	2.8346	15.000	15.88	12	.433	7.75	3.00	3.25	1.44	2.12	.88
411256FO5	3.75	6.00	12.375	11.625	8	.406	1.024	2.165	15.000	15.88	12	.433	7.75	3.00	3.25	1.44	2.12	.88
411256FO7	3.75	6.00	12.375	11.625	8	.406	.937	2.440	15.000	15.88	12	.433	7.75	3.00	3.25	1.44	2.12	.88
434630FO1	3.75	6.00	12.375	11.625	8	.406	1.1875	2.8346	15.000	15.88	12	.433	7.75	3.00	3.25	1.44	2.12	.88
434630FO2	3.75	6.00	12.375	11.625	8	.406	.937	2.440	15.000	15.88	12	.433	7.75	3.00	3.25	1.44	2.12	.88
434630FO3	3.75	6.00	12.375	11.625	8	.406	1.1875	2.8346	15.000	15.88	12	.433	7.75	3.00	3.25	1.44	2.12	.88
436003FO	3.75	6.00	12.375	11.625	8	.406	1.1875	2.8346	16.875	17.75	12	.433	9.75	3.00	3.35	1.44	2.12	.88
436003FO1	3.75	6.00	12.375	11.625	8	.406	.937	2.440	16.875	17.75	12	.433	9.75	3.00	3.35	1.44	2.12	.88
434240FO	3.75	6.00	12.375	11.625	8	.406	1.1875	2.8346	16.875	17.75	12	.433	9.75	3.00	3.35	1.44	2.12	.88
434240FO1	3.75	6.00	12.375	11.625	8	.406	.937	2.440	16.875	17.75	12	.433	9.75	3.00	3.35	1.44	2.12	.88
431271FO	3.75	6.00	12.375	11.625	8	.406	1.1875	2.8346	18.375	19.25	12	.433	9.75	3.00	3.25	1.81	2.12	.88

**Allowable Side Load Pulls:**

The following formula can be used to calculate applied side load. Loads are calculated on proper tensioning of belts. If belts are tightened excessively, the resulting side load can exceed these limits

$$L = \frac{126000 \times \text{H.P.}}{N \times D} \times F \times A$$

- L** = Actual Applied Load (lbs.)
- N** = Shaft Speed (rev./min.)
- D** = Pitch Diameter of Sheaves, etc. (in.)
- F** = Load Factor (see below)
  - 1.0 for chain
  - 2.5 for V belt drive
  - 3.5 for flat belt drive
- A** = 1.0 for low & moderate duty drives
  - 1.4 for severe duty shock loads or large inertia loads (reciprocating compressors, crusher, chippers, planers, etc.)

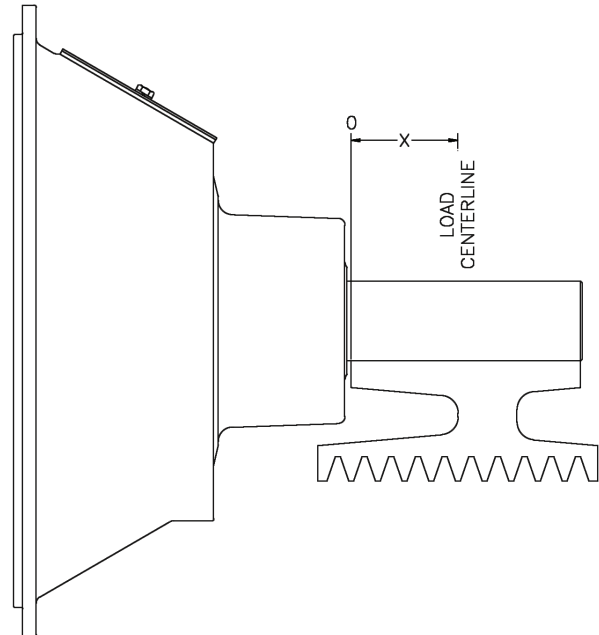

**Required Clutch Torque Capacity Calculation:**

Required Clutch Torque = Maximum Engine Torque x Service Factor

**Blower or Vacuum**

- Centrifugal with free flow of air ..... 1.7
- With high start-up inertia or subject to choking of air supply ..... 4.0

**Compressors**

- Reciprocating, 1 or 2 cylinders ..... 4.0
- Reciprocating, 3 or more cylinders ..... 2.5
- Roto screw or turbine ..... 2.0

**Conveyor**

- Fed uniformly ..... 1.5
- Not fed uniformly ..... 2.0
- Reciprocating ..... 3.0

**Drills** ..... 2.0

**Generator**..... 2.0

**Pump**

- Centrifugal or turbine ..... 1.5
- Dredge ..... 2.0
- Mud or reciprocating ..... 3.0

**Rock Crusher, Hammer** ..... 3.0

**Mill Snow Blower**..... 2.0

**Wood Chipper, Saw Mill** ..... 3.0

**Power Take-Off Part Numbers**

411256FO3, 411256FO7,  
434630FO2, 436003FO1, 434240FO1

RPM	X" Distance					
	0	1"	2"	3"	4"	5"
1600	2900	2200	1650	1300	1075	925
1900	2775	2100	1575	1240	1025	875
2200	2650	2000	1500	1180	975	825
2500	2525	1900	1425	1120	925	775
2800	2400	1800	1350	1060	875	725

**Power Take-Off Part Numbers**

411256FO5

RPM	X" Distance			
	1"	2"	3"	4"
1600	2150	1575	1250	1025
1900	2050	1500	1175	975
2200	1950	1425	1100	925
2500	1850	1350	1025	875
2800	1750	1275	950	825

Manufacturers names, symbols and numbers are for reference purposes only and do not imply manufacturing origin.